



USER MANUAL

MODEL 1684 AUTOMATIC SPRAY GUN CLEANER



Heritage-Crystal Clean, LLC
2175 Point Blvd. Ste 375
Elgin, IL 60123
Tel. 1-877-938-7948

REV 2019-06

INTRODUCTION

Every machine is tested for compliance with Quality Assurance standards. Follow the directions in this manual under SETUP, OPERATION and MAINTENANCE in order to operate this machine safely and effectively. Not following these instructions can lead to malfunction or damage to the machine. Ensure that this manual is readily available for the operator at all times. If you have any questions about the operation of this machine, call Heritage-Crystal Clean Service Engineer at 1-877-938-7948.

COMMON FEATURES

- Cleans pressure pots up to 8" high and one spray gun in one cycle.
- Automatic Wash, Air Flush, Solvent Rinse to clean spray gun and pressure pot.
- Flow-through Brush for manual wash.
- Spigot for manual rinse.
- Stainless steel inlet filter, located at the end of the suction hose, prevents debris from reaching the pump and wash pail.
- 14 Cleaning Jets with swirl action.
- Shipping Size and Weight: 38" W x 26" D x 68" H, 185 LBS 84 KG.

CAUTIONS AND WARNINGS

- Always disconnect this machine from air supply before performing maintenance.
- Make sure all ground wires are connected and that unit itself is grounded properly.

SAFETY EQUIPMENT

- Wear safety eye ware and protective clothing.
- Wear deluxe extended length neoprene gloves; SAS PN 6588 or Thicksters PN 6602-20 through 6605-20.

SETUP

DELIVERY INSPECTION

- Inspect the shipping carton for any sign of transport damage. Carefully remove the unit from the shipping carton and check the unit for damage. Report any transport damage immediately to the carrier and to Heritage-Crystal Clean. Initiate a freight claim with the carrier.

LOCATION

Position the unit in a ventilated area at least 6 " from the back wall.

HCC75W

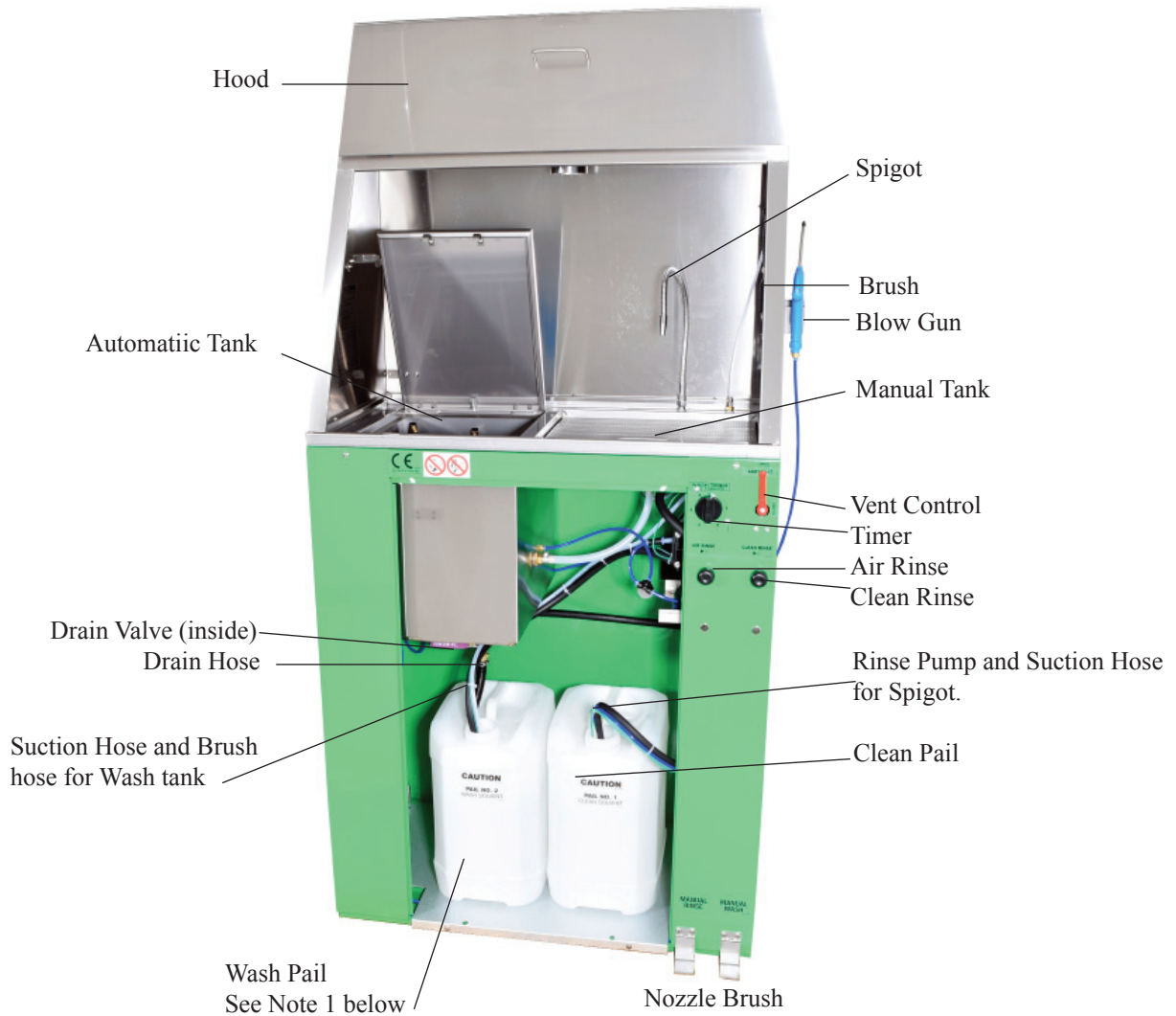

Wash Pail

Note 1: The wash and Rinse pails are provided by Heritage-Crystal Clean. The stainless steel inlet filter, located at the end of the suction hose, prevents debris from reaching the pump and wash tank. The procedure to clean the filter is described in the Section, MONTHLY MAINTENANCE.



Suction Hose

Stainless steel inlet filter located on end of suction hose

ACCESSORIES:

See below.

QTY	ACCESSORIES	PART NO.
1	MANUAL	
1	TRIGGER CLAMP & PLUG KIT, SET OF 2	140-2340
1	AIR BLOW GUN (INSTALL ON RIGHT SIDE OF UNIT)	102-7010
1	VENT AND HOOD DOOR SUPPORT	780-3723
1	CLEANING KIT FOR SPRAY GUN	KIT-GCTOOLS
1	3" DIAMETER VENT HOSE / CLAMP	780-524/112-261
	NOZZLE EXTENSIONS:	
1	FOR DISPOSABLE CUP SYSTEMS. MAY ALSO BE USED TO CLEAN CONVENTIONAL CUP SYSTEMS.	110-430PPS
1	FOR CONVENTIONAL CUP SYSTEMS WITH SMALLER OPENINGS IN THE NECK.	110-430
1	FOR DISPOSABLE CUP SYSTEMS INCLUDING MANY PPS2 ADAPTORS	110-430PPS2
1	NOZZLE EXTENSION, FOR USE IF CONVERTING TO A 2 GUN CLEANER	110-356

AIR SUPPLY

- Connect a male 1/4" NPT air supply plug (not supplied) into the female Air Inlet on the unit.
- Connect the female air supply hose to the plug. The air supply hose must be at least 3/8" inside diameter. **The air supply pressure must be at least 85 PSI and the supply air must be free from contaminants such as water, dust, rust, tar and grease. If the air supply is not clean and dry, install a moisture filter. The operation and longevity of the pump and other components depends on the presence of clean and dry supply air.**
- To prevent damage to the Diaphragm Pump an internal Air Pressure Regulator has been installed to limit the air pressure to 85 PSI. Do not install a second air pressure regulator or use a pressure set below 85 PSI.

GROUNDING

- Connect the green ground wire at the back of the unit to a ground in the building using the ring terminal on the ground wire.

Note: The pump and metal tube that inserts into each pail are grounded.

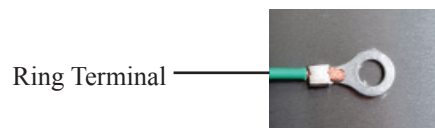

INSTALLATION OF VENT AND HOOD SUPPORT

- The vent kit is located in a box in the cabinet. Locate the hole for the vent on the underside of the top of the cabinet. See photo to the right and below, left.
- Push the vent through the hole and install one screw in the front screw hole. Hold the vent in place if necessary and reach on top of the cabinet to install a wing nut onto the screw. See the photo in the lower left below.
- Install the 3 other screws and wing nuts in a similar way. To not tighten the wing nuts.
- Connect blue airline located near the vent on the inside of the sink to the vent. See photo on right.
- Place the Hood Support between the wing nut and the top of the cabinet. Tighten the 4 wing nuts. See the photo below right.

Vent Location



Vent at Top of Cabinet

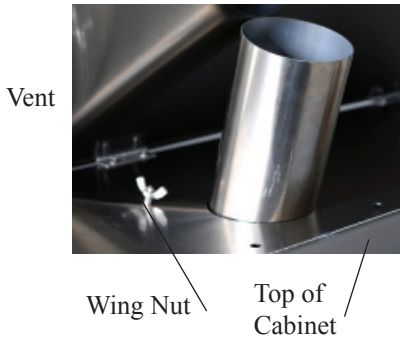

Hood Support

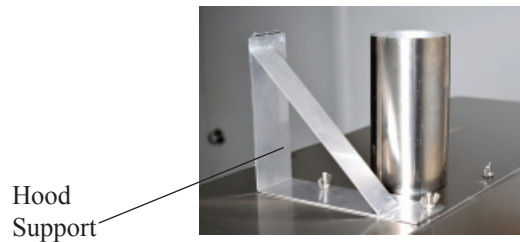

OPTION - CONVERTING THE TANK TO A 2 SPRAY GUN CLEANER

Wash Tank

- The post of the Rotating Jets can be replaced with a nozzle from the accessory kit, part 110-356 (see drawings of replacement parts) to convert the tank to a 2 spray gun cleaner.
- To remove the post of the Rotating Jets you will need 2 spanners. One spanner grips the nut (not seen) below the post of the Rotating Jets and one spanner grips the nut at the bottom of the post of the Rotating Jets. Hold the spanner on the nut below the post of the Rotating Jets steady and turn anti-clockwise the nut of the post of the Rotating Jets.
- Install the Nozzle Extension, 110-356.

Rotating Jets

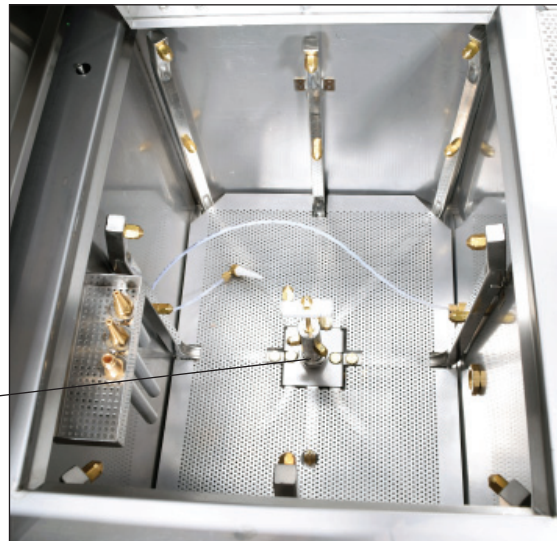

PAIL SETUP

- Remove the cabinet door.
- Heritage-Crystal Clean provides a wash pail and a clean pail. The wash pail has 3 gallons of solvent and the clean rinse pail has 5 gallons of solvent. Place the wash pail on the left side in front of the cabinet and the rinse pail on the right side.
- Close the drain valve (horizontal position) to stop solvent dripping from the cleaning tank. See photo of the Drain Valve below.
- Insert the black convoluted drain hose into the back hole of the wash pail. See photo below. Insert the suction hose and brush hose into the front hole of the wash pail. See the photo of the unit below. Open the drain valve (vertical position) located inside the cabinet. See photo below. Place the wash pail in the left side of the cabinet.
- The rinse pump is the stainless steel tube located in the bottom of the cabinet. Insert the rinse pump and tube for the spigot into the opening and place the 5 gallon pail of solvent in the cabinet on the right side. Check to ensure the Drain Valve is in the open position (handle in vertical position)

Drain Valve - Open



Drain Valve - Closed

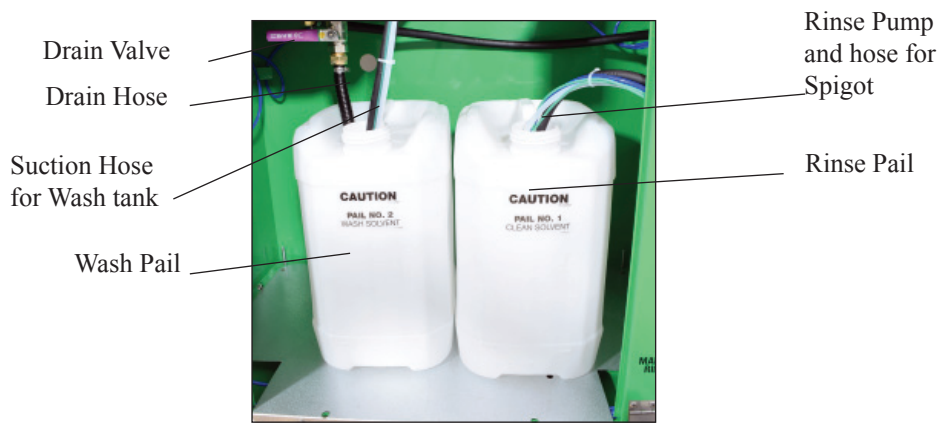

The stainless steel inlet filter is located at the end of the suction hose and prevents debris from reaching the pump and wash tank. See the photo of the filter at right. Clean the filter monthly. The procedure to clean the filter is described in the Section, MONTHLY MAINTENANCE.

Stainless Steel Filter

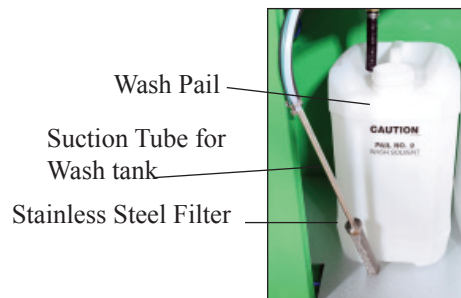

ALUMINUM VENT HOSE

Stretch the 3" diameter aluminum vent hose. Use the clamp to attach this vent hose to the solid vent tube at the top of the cabinet of the 1684. The other end of the vent hose is connected to the venting system.

CLEANING SPRAY GUNS AND CUPS

Pour paint waste from the paint channel of the spray gun into a waste drum.

- Remove digital air gauge if so equipped.
 - Loosen the air cap of the spray gun two full turns.
 - Lock the trigger in the open position with the Trigger Lock Spring.
- See photos below.



Remove Gauge

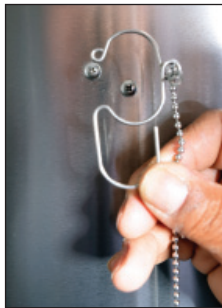

Trigger Lock Spring



Trigger Lock Spring On Spray Gun

INSTALLING SPRAY GUNS IN TANK

- Center the pressure pot on the Rotating Jets in the middle of the tank. Maximum height 8". See the photo below.
- Place the spray gun on the nozzle extension with the cap facing the corner. See photo below.

WASH TANK

PLACING SPRAY GUN ON PUSH ON NOZZLE EXTENSION

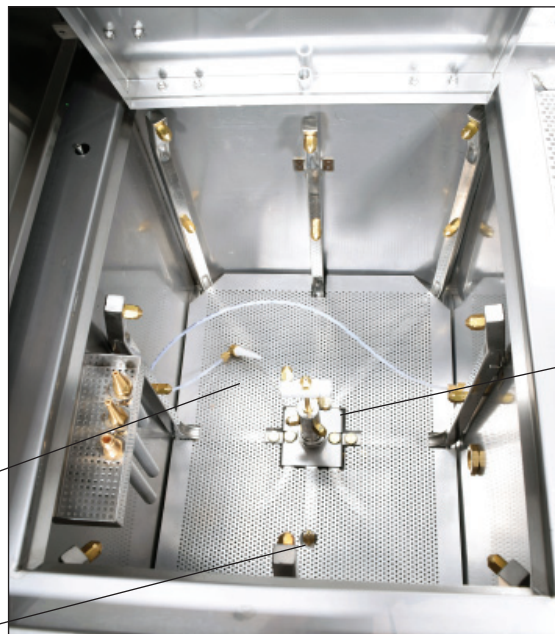

Air Plug

Location for Push On Nozzle Extension for second spray gun

Rotating Jets, Center the pressure pot over the Rotating Jets

TRAY TO HOLD NOZZLE EXTENSIONS
(left side of tank)

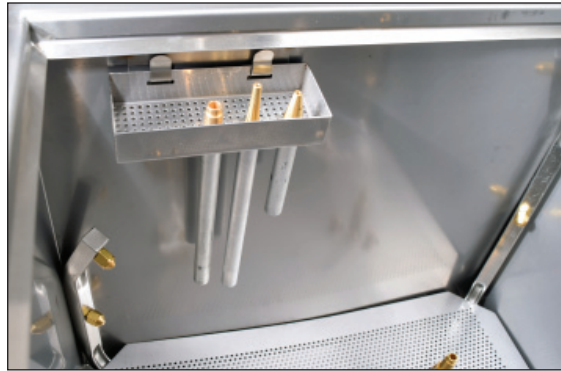

DIFFERENT TYPES OF SPRAY GUNS
ON NOZZLE EXTENSION

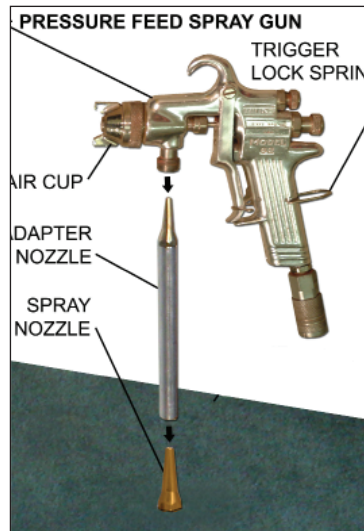
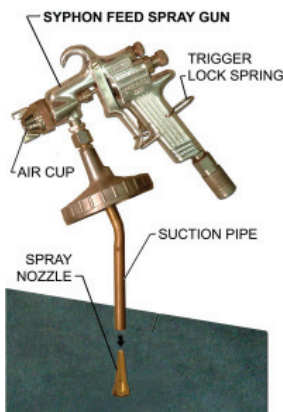
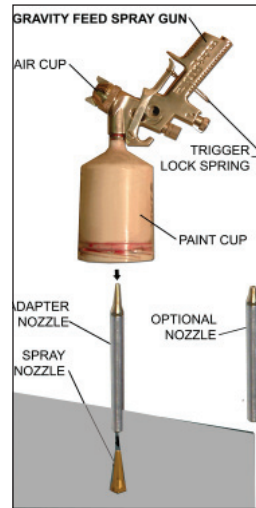
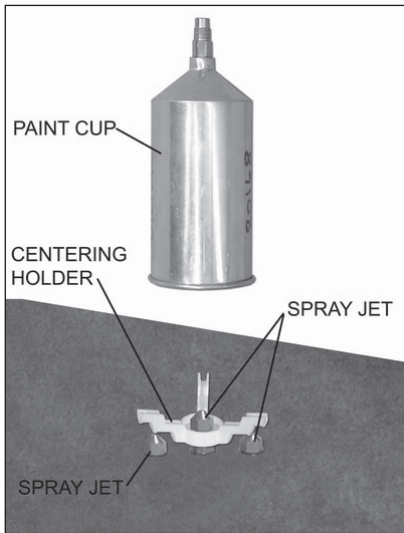

PREVENT SOLVENT FROM ENTERING THE AIR PASSAGE OF THE SPRAY GUN

- Insert the plastic plug into the air fitting as in the photo at right.
- Positive air will flow through the passage way during cleaning.
- If you disconnect the air plug from the spray gun attach the knurled nut to the air passageway of the spray gun. The knurled nut is located on the chain with the trigger lock spring.



Air Plug inserted into the Air Passage way of the spray gun

Cleaning Cycle:

- Close the lid of the spray tank and turn the "Auto Wash Timer" clockwise. See photo below. The maximum time is 5 minutes.
- Push and hold the "Air Rinse" button for about 5 seconds to evacuate the wash liquid and air rinse the spray guns. See photo below.
- Press and hold the "Clean Rinse" button for about 5 seconds to send 100 cc of clean liquid through the jets to rinse the spray guns. See photo below.
- Press the air rinse button for 5 seconds.

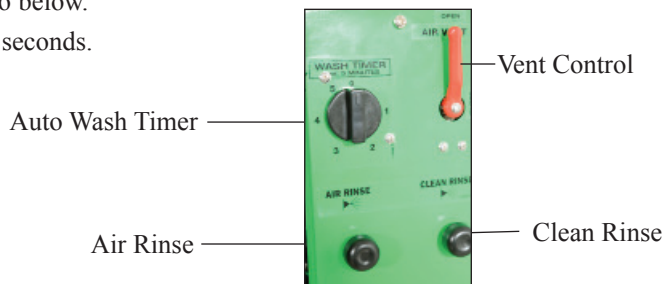

MANUAL WASH

- Use the brush to manually clean the outside of the spray gun. See the photo below. The brush is located on the wall of the right side of the tank. Step on the foot pedal to activate water flow from the wash pail. See the photo on page 3 for the location of the brush and foot pedal.
- Rinse the spray gun or pressure pot using the spigot. Step on the foot pedal to activate solvent flow from the clean solvent pail. See the photo on page 3 for the location of the nozzle and foot pedal.



MAINTENANCE

- Clean the stainless steel inlet filter each month.

Procedure:

Follow step 1 and step 2 below under REPLACING SOLVENT.

Lift the suction pipe from the wash pail, (see the left photo below) unscrew the stainless steel filter from the nut, by hand, and clean it with clean solvent. See the right photo below.

Remove Suction Pipe and Filter



Clean Filter



REPLACING SOLVENT

- 1) Remove the clean pail (right side) from the cabinet and then remove the rinse pump and tube for the spigot from the clean pail.
- 2) Close the drain valve (left photo below). Remove the drain hose and suction pipes from the wash pail and take the pail out of the cabinet. See middle and left photo below.
- 3) Replace the pail of wash solvent with a fresh pail of wash solvent. The replacement pail contains 3 gallons of clean wash solvent. Top up the clean water pail to 5 gallons. Return the pails to the cabinet.
- 4) Open the drain ball valve (vertical position)

DRAIN VALVE - CLOSED POSITION



WASH AND CLEAN RINSE PAIL



SUCTION PIPE WITH INLET FILTER

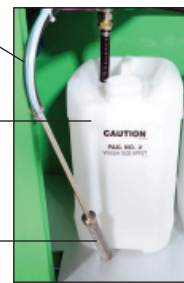

Suction Tube

Wash Pail

Clean Rinse Pail

Inlet Filter

TROUBLE SHOOTING

PROBLEM	REASON	CORRECTIVE ACTION
PUMP MAKES PUMPING SOUND BUT LIQUID DOES NOT FLOW THROUGH THE JETS.	Drain valve closed	Open drain valve (put in vertical position), if not already open
	Liquid level too low	Check wash liquid level. Add liquid if less than 1/2 full.
	Debris in pump or suction and output hose	Follow Procedure 1, "Blocked Fluid Passage in Diaphragm pump" in the next section.
WASH PUMP MAKES HISSING SOUND AND LIQUID DOES NOT FLOW.	Water or contaminants in air line of pump.	Follow Procedure 2. "Blocked Air Passage in Diaphragm Pump" in the next section.
BRUSH PUMP DOES NOT MAKE A NOISE AND LIQUID DOES NOT FLOW WITH PEDAL DEPRESSED	Foot pedal switch not functioning	Inspect foot switch for free travel, and lubricate with gun oil. If switch will not travel freely, replace with PN 155-400BF2
WASH PUMP DOES NOT STOP UNLESS TIMER IS TURNED BY HAND OR AIR IS SHUT OFF. WASH PUMP DOES NOT START.	Defective Timer	Replace Timer. (115-200K)
TIMER KNOB SPINS BACK WHEN TURNED	Defective Timer	Replace Timer. (115-200K)
INSIDE WALL OF TANK IS COATED WITH PAINT EVEN THOUGH OPERATOR MAINTAINS TANK	Liquid lacks cleaning strength.	Use new solvent and/or better solvent or, for water cleaning, add Aqua-Kleen.
GUNS NOT CLEAN, PUMP WORKING, LIQUID FLOW IS NORMAL	Trigger not locked in open position	Use Trigger Lock Spring. (120-350)
	Spray gun is not properly installed on to nozzle	Re-install with proper adapter
	Liquid lacks cleaning strength.	Use new solvent and/or better solvent or, for water cleaning, add Aqua-Kleen.
	Low pressure in air supply	Increase air pressure to a minimum of 85 PSI.
	Plugged jets.	Remove and clean by blowing air through the jets. If not successful, replace the jets or, if still not successful, replace the whole Delivery Tube Assembly.

PROBLEM	REASON	CORRECTIVE ACTION
GUNS NOT CLEAN, WASH SOLVENT IS MILKY WHITE	Wash solvent is contaminated with water	Replace cleaning agent
SOLVENT APPEARS RED OR ORANGE	Water in solvent is corroding the metal pail.	Replace or recycle wash solvent. Use HDPE pail approved for use with solvent.
DEPRESSING CLEAN RINSE BUTTON DOES NOT PROVIDE CLEAN LIQUID	Rinse pump is leaking	Replace rinse pump. (URP100S-F)
CLEAN RINSE LIQUID IS DIRTY		Replace Combination Valve. (UVB-400KIT)

TROUBLESHOOTING PROCEDURES

PROCEDURE 1

The 5" diaphragm pump, UDP5TA, powers the wash tank and a UDP2TAB pump powers the brush and spigot. 5" Diaphragm Pump, UDP5TA for Wash Tank:

- If the pump sounds like it is working but liquid does not flow into the wash tank, clear the fluid passage as follows:
Remove the suction tube from the wash pail and blow air at 85 PSI into the Inlet Solvent Hose (see diagram below and the Flow Diagram). Turn the timer.
- Repeat these steps several times. If this procedure does not help, disconnect the output hose at the combination valve. See the flow diagram. Point the end of the output hose into the wash pail. Activate the pump. If liquid does not flow through the output hose replace the pump. If liquid does flow remove the blockage in the delivery tubes or jets.

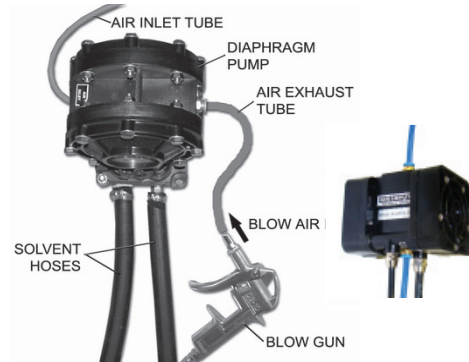

UDP2TA:

- Remove the suction tube from the pail and blow air at 85 PSI into the INLET Sovent Hose. Step on the foot pedal to activate the pump for the brush. This procedure may have to be repeated several times. If this procedure does not help, disconnect the output hose at the tank wall. See the flow diagram. Point the end of the output hose into the wash pail. Activate the pump by stepping on the foot pedal. If liquid does not flow through the output hose replace the pump. If liquid does flow clear the blockage upstream. The warranty on the diaphragm pump is two years from date of purchase.

PROCEDURE 2

Blocked Air Passage In Diaphragm Pump

If there is a steady hissing sound and the pump is not cycling, the spool valve has stalled due to a blocked air passage. Follow the procedure below to clear the blockage.

- Connect a blow gun to an 85 PSI source. Locate the blue hose that extends from the air exhaust port of the diaphragm pump. Use a blow gun to blow air into the open end of this hose. Turn timer. If the procedure is successful, the pump will start working. The procedure may have to be repeated several times. If this procedure does not work, replace the pump.
- Cause:** Contaminants in the air supply (water, oil, solid particles etc)
- Preventative Action:** If necessary, install an Airline (Moisture) Filter.

PROCEDURE 3

Blocked Passage in Air Line

The components in the air line are the **diaphragm pump, air valve, foot pedal, 3-way ball valve and regulator**. See the **Flow Diagram** and the section: **Replacement Parts**.

To troubleshoot a component:

- 1) Disconnect the air line to the component using the quick disconnect.
- 2) Step on foot pedal and check for presence of positive air pressure in the air line. If there is ample positive air pressure, replace the component.

If air pressure is absent, there is a faulty component downstream. Reconnect the air line and check the operation of the next component upstream by following steps 1 and 2 above.

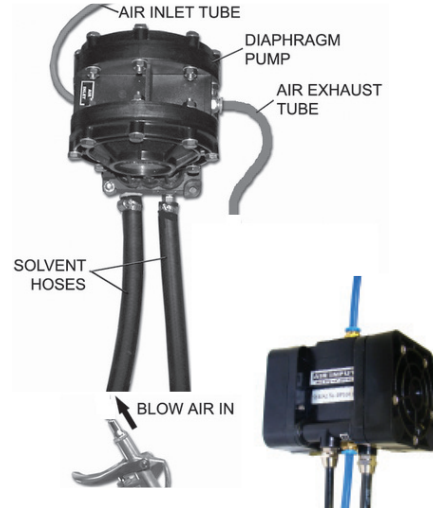

HCC75W FLOW DIAGRAM

Use the diagram to trace the flow of compressed air and liquid.

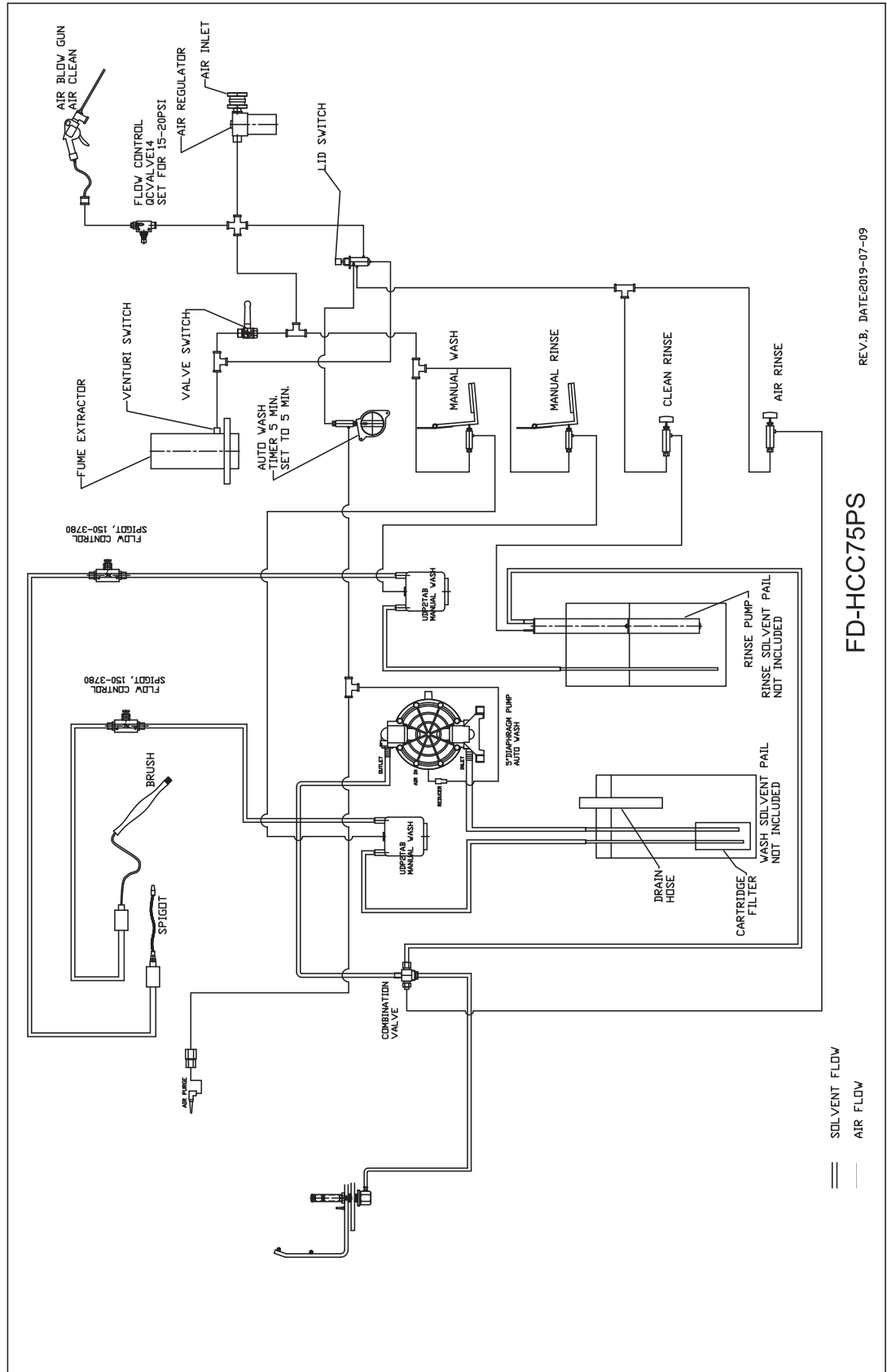

FD-HCC75PS

REPLACEMENT PARTS

PART NO.	ACCESSORIES
780-3723	VENT AND HOOD DOOR SUPPORT
140-2340	TRIGGER CLAMP & PLUG KIT, SET OF 2
780-3530	INSTALLED NOZZLE EXTENSION TO CLEAN DISPOSABLE CUPS
102-7010	AIR BLOW GUN (INSTALL ON RIGHT SIDE OF UNIT)
780-524/112-261	3" DIAMETER VENT HOSE AND CLAMP
ITEMS BELOW ARE SHOWN ON THE ATTACHED PAGE.	
110-430PPS	HOLES ALLOW LIQUID TO CLEAN DISPOSABLE CUP ADAPTOR. MAY ALSO BE USED TO CLEAN CONVENTIONAL CUP SYSTEMS.
110-430	FOR CONVENTIONAL CUP SYSTEMS WITH SMALLER OPENINGS IN THE NECK.
110-430PPS2	FOR DISPOSABLE CUP SYSTEMS INCLUDING MANY PPS2 ADAPTORS
110-356	NOZZLE EXTENSION FOR CONVERTING TO A 2 SPRAY GUN CLEANER
780-2701F	SPIGOT
115-200K	TIMER AND VALVE ASSEMBLY
140-2341	TRIGGER CLAMP, CHAIN AND PLUG, SINGLE
100-835-6	GROUND WIRE, 18AWG, GREEN, 1300MM, W. 1/4" RING TERMINAL.
100-8330	GROUND WIRE, GREEN, 14 AWG X 4 FT LONG
780-2210	REMOVABLE BASKET, FOR HCC75W/HCC75PS
140-230	AIR PASSAGE PLUG WITH TUBE, NYLON
120-4200TDM	DUAL TUBE + FILTER 104-4206, SINGLE, 30 MESH, 30MM DIA
780-75010F	FOOT PEDAL WITH HINGE WELDMENT, FOR ALL EXCEPT IWJ 780-75010F 780-010F
115-400	RINSE VALVE ASSY, 2WAY, HEAVY DUTY, M10 THREAD,
780-3940	FLOW CONTROL VALVE
144-390S	SOLVENT BRUSH+ 6 MM COMP. FITTING + TUBE
102-7010	AIR BLOW GUN, 4" ASSEMBLY, PLASTIC, WITH 4FT TUBING
NYT4X6	SUPER SOFT NYLON TUBE, 4mm ID x 6mm OD, SEMI-CLEAR WHITE
UDP2TAB	2" DIAPHRAGM PUMP, TEFLON BALLS, BRASS BARBS
102-020PR	PRESSURE REGULATOR ASSY, WHIP LINE
UDP5TA	DUAL DIAPHRAGM PUMP, 4"
URP100S	RINSE PUMP ASSY, SS, 100CC, BOTTOM PORT

REPLACEMENT PARTS

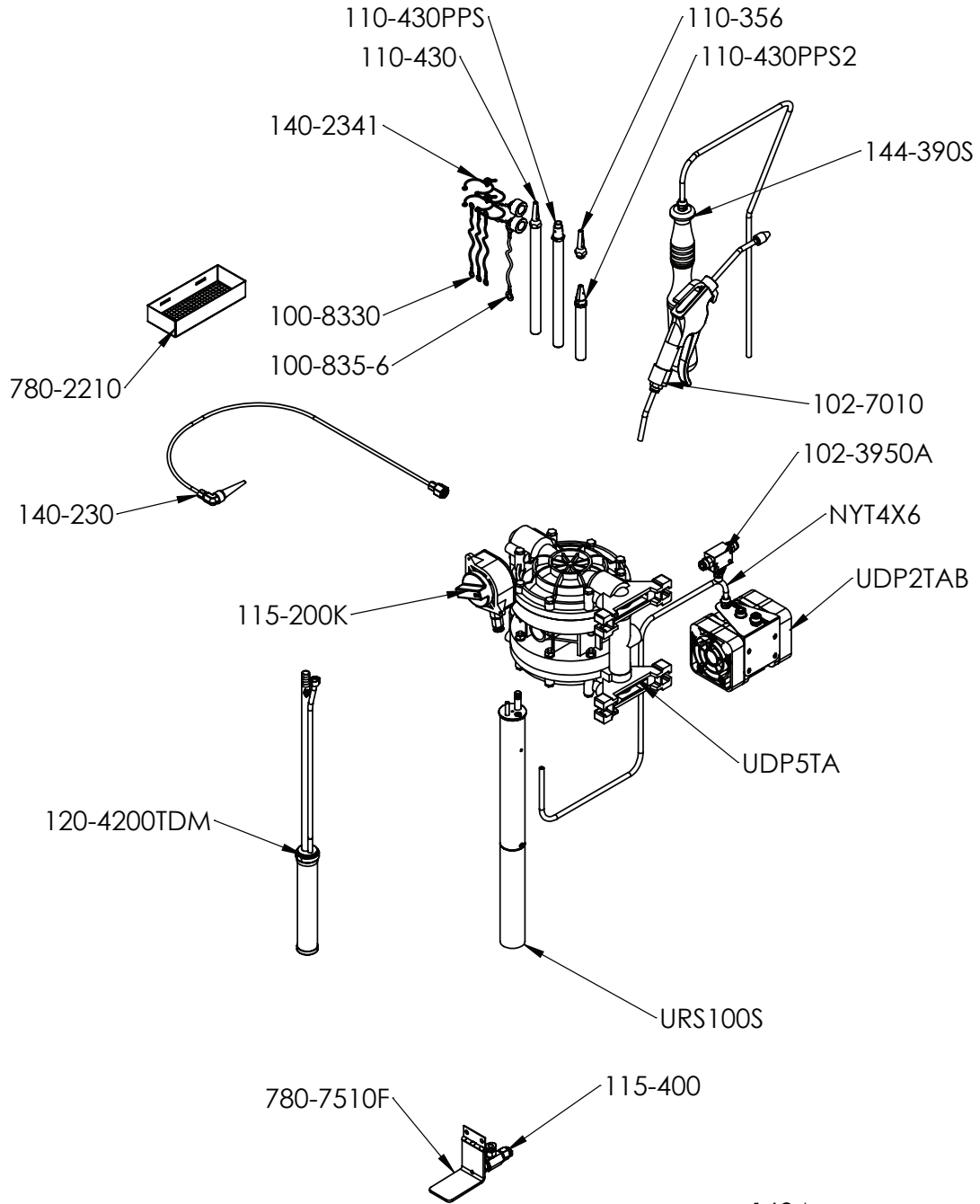

1684
REPLACEMENT PARTS



Full Product Warranty

These Heritage-Crystal Clean products have been engineered and manufactured to high performance standards. Each unit has been subjected to detailed factory testing before shipment.

This product comes with a one-year full warranty from the date of purchase. Heritage-Crystal Clean Corporation reserves the right to repair or replace the unit, free of charge, to the original purchaser if a part is found to be defective in material or workmanship as determined by factory service personnel. The items listed below under "Conditions of Warranty" as consumables are not covered.

Heritage-Crystal Clean reserves the right to direct the customer to ship the unit collect to the Heritage-Crystal Clean factory or to an approved Service Center for repair using the Heritage-Crystal Clean Return Goods Procedure or to repair the unit on-site. To prevent damage in transport, the purchaser must ship the unit in the original packaging or use alternate adequate packaging. All units must be shipped clean and free of liquid.

Diaphragm Pump:

We are pleased to advise that the warranty on the diaphragm pump, the heart of the spray gun cleaner, comes with a 2 year replacement warranty. If, in the unlikely event your diaphragm pump fails during the first two years of service, call Heritage-Crystal Clean Service at 1-877-938-7948. We will send you a new pump free of charge and arrange for the return of your original pump.

Conditions of Warranty:

As Heritage-Crystal Clean Corporation has no control over the working conditions or circumstances under which the purchaser stores, handles or uses the product, Heritage-Crystal Clean makes no warranty or claim, either expressed or implied with respect to this product's fitness for any purpose or the result to be obtained from its use. This condition applies to the sale of all products and no representative or distributor of Heritage-Crystal Clean Corporation has the authority to waive or change these conditions.

This warranty applies only to the original purchaser and does not apply if the unit has been misused, overloaded, neglected, altered or used for any purpose other than those specified in the operating and installation instructions. Deterioration due to normal wear is not covered by this warranty. Damage due to accident, transportation, fire, floods or acts of God is also not covered. Units whose serial numbers have been altered or removed are not covered. The warranty is invalid if unauthorized chemicals as noted in the manual or liquids with acid content are used in this unit. Unauthorized attempts at self-repair or alterations by the owner also invalidate this warranty. Interior or exterior finishes are not covered by this warranty.

Consumable Items are not covered by this warranty (eg: gaskets, screens, bags, filters, nozzles and air jets).

This warranty replaces all other warranties expressed or implied by statute or otherwise.

To make a claim, call Heritage-Crystal Clean Service at 1-877-938-7948 and quote the serial number of the unit.